



RUBIX
CUTTING &
MACHINING



Machining Application Support

Helping our customers
to remain competitive
and profitable



CUTLINE

Machining Application Support

We know manufacturing and industry demand outstanding support. Working with the leading suppliers of cutting tool technology and fluid management our Applications Engineering Technical Support provides:

- Application Engineering solutions to our customers
- Access to our practical tooling and training centre
- The best solution for your applications
- Closer working relationships with customers, technical experts and suppliers
- The latest product innovations from leading suppliers
- Engineered solutions and feature based projects



Delivering Tangible Cost Savings

Our solutions will help you:

- › Reduce machining times
- › Increase tool life
- › Rationalise tooling usage
- › Improve productivity on high value applications
- › Optimise and improve processes

Services provided

- › Remanufacturing and re-engineering
- › Holding and balancing – demonstrating benefits
- › Fluids and fluid management
- › Solutions for tool holding, work holding and tool storage
- › Feature based programming support
- › 2D and 3D CAD/CAM

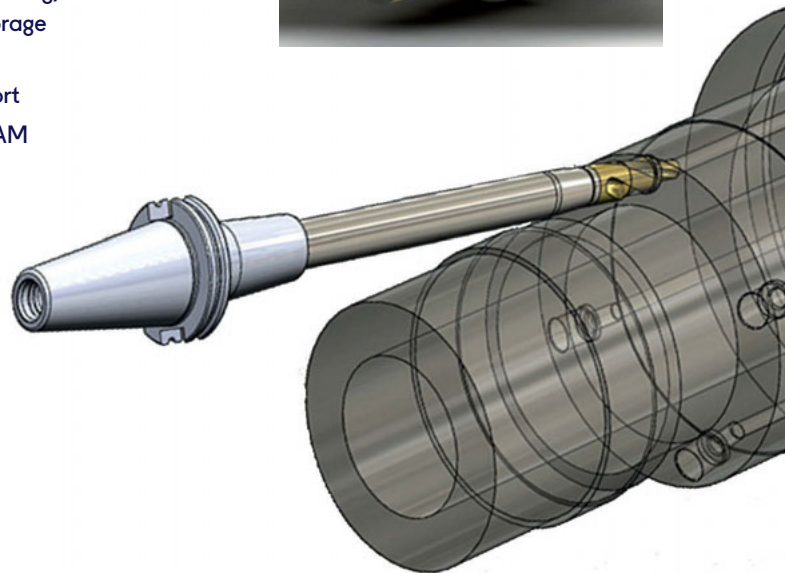

On site Product Proving Centre and training

Our Product Proving Centre facilities include the latest CNC machines to trial the leading machining and tooling technology. Using real parts, with real tools on real machines, our specialist application team are able to demonstrate achievable savings for customers. The centre offers a range of services:

- › Offsite prove-out application support, no need for downtime, we'll programme and test the solution first. All you need to do is implement it.
- › Industry relevant machining capabilities up to 5 axis.
- › We'll give you the best solution for your application
- › Practical demonstrations to prove and test tooling options
- › We are distributors of the leading cutting tool suppliers
- › Demonstrate and apply new advanced tooling and procedures
- › Reports to demonstrate benefits and cost savings
- › Continuous improvement on all current and future production processes
- › Time-served engineering expertise
- › Latest CAD/CAM strategies coupled with tooling know how

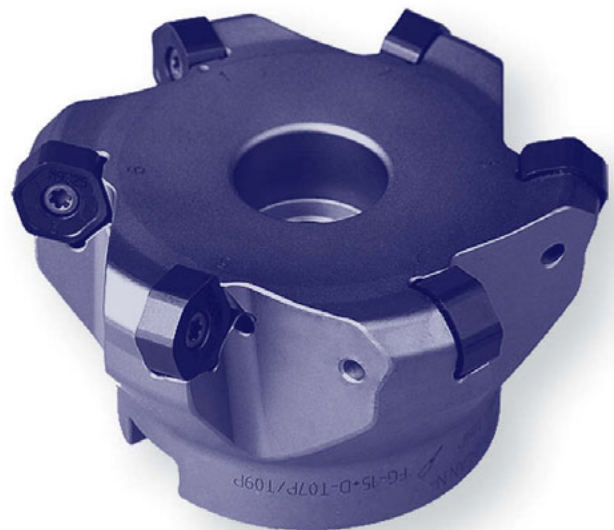
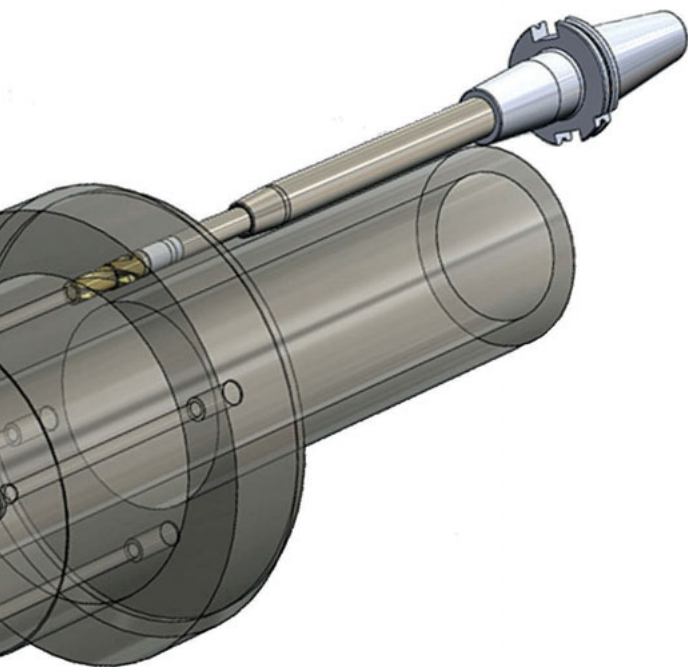

*Toolpaths generated
from cutting tool knowledge;
we don't just cut pixels*

Delivering Measured Cost Reductions

By understanding today's market needs for delivering cost reductions, we are able to deliver tailored solutions for our customers. Whilst working closely with your engineering team we deliver expert solutions for each component undertaken by our team of experienced engineers. When projects are completed we'll present clear, concise, unbiased tooling and real-world information to prove the effectiveness of solutions available.

How we do it

- › We listen to and understand the parameters required to deliver a bespoke solution to our customers.
- › We benchmark all of our customer's existing data and methodology and capture this data at source. This includes an on-site survey of all processes and plant/equipment.
- › Proposed improvements will be assessed and put forward to your engineering team. Concepts can be trialled on-site or at our Product Proving Centre.
- › We provide fully documented detailed cost saving files showing all savings delivered. These are presented in a cost per part format to the end user, to indicate exactly where the cost savings can be achieved.
- › Ongoing support throughout the lifespan of the component will be provided to keep you in touch with the latest technologies that could deliver future additional benefits to you.

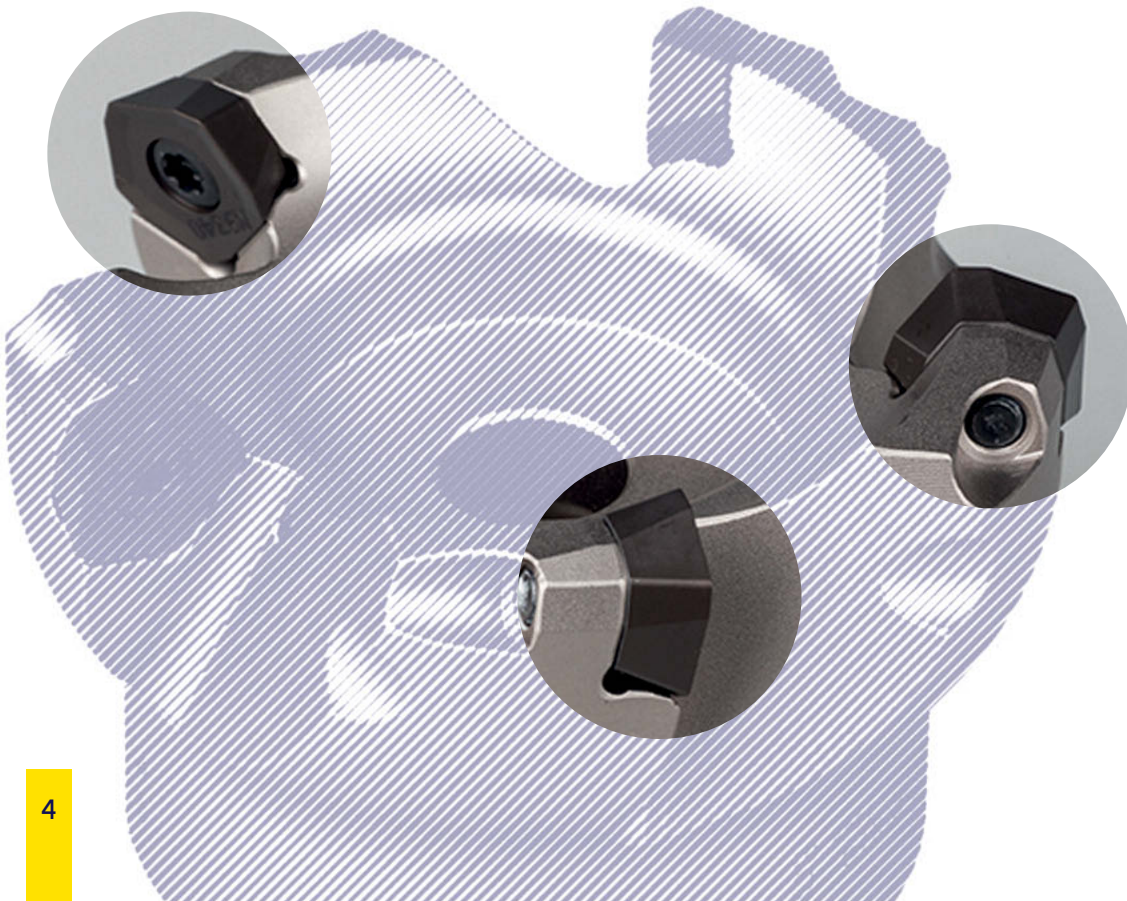

Case Studies

CASE STUDY 1: Sector: Aerospace



Outcomes: **Doubled feed rate, increased tool life**
Cost saving: **£1,400 per 54 parts**
The tool saving over a production batch of 5,000 parts was **£6,964**

A customer in the aerospace industry needed to increase the amount of parts their machine was producing.

By replacing their current high feed cutter with the latest generation of high speed cutters, we were able to double the feed rate from 1,100 mm/min up to 2,180 mm/min reducing the roughing

cycle from 1 hour to just 34 minutes. This resulted in a saving of 24 hours machining time for every 54 parts the customers produced allowing them to produce more parts far more cost effectively. The tool life also increased, as cutting tool inserts needed replacing after 10 parts, when previously replacements were needed after production of only 4 parts, resulting in further cost savings and even less down time.



CASE STUDY 2: Product proving a win for customer



Outcomes: **Manufactured engineered solution allowed the customer to win their contract to machine these parts.**

The Customer had a reach problem in order to manufacture ports on a tubing hanger.

We designed the port tools, modelled the component, and created an assembly of the component and the tool build-ups required. This showed the access needed and proved the concept.

The manufactured engineered solution we provided, with full tooling methodology, allowed the customer to win their contract to machine these parts.

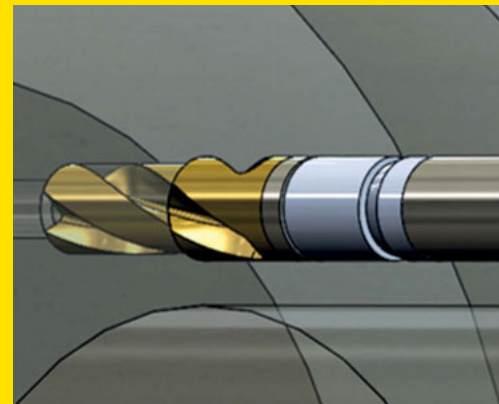

Deliverables

Realistic proposal

We'll work to ensure the proposal is both practical and reasonable in terms of resources; machine time and people.

Detailed reporting for easier decision making

Our Time Study, Cost Savings Reports, Guided Recommendation and Outputs provide extensive information to aid decision making.

Follow up

We commit to working with you beyond the life of this review, ensuring optimal process and productivity as appropriate.

Cost saving documentation



To supply individual feature based cost saving reports or complete project reports

Using all data from your current process alongside new actual data from on site or off site physical trials for clear comparisons

Specific milling/turning cost saving reports

In depth data from process comparisons

- ▶ Cost savings per batch
- ▶ Cycle time savings
- ▶ Down time cost savings
- ▶ Cost savings per annum

Cost Saving Report – Example

Cost Saving Report
– Turning

Cutting Data
– Time

Insert Code	Chip Breaker	Grade	Part Diameter (mm & start diameter)	Speed (Vc)	RPM	Feed (mm/rev)	Linear feed (mm/min)	Depth of Cut (ap)	Length of pass	Time in cut	Number of passes	Total time per part	Time Saved (Per Part)	Time saved over production
CNMG 120408	**	****	800	160	64	0.25	16	2	200	0.008727778	3	00:37:42		
CNMG 120408	**	****	60	190	1008	0.3	302	5	200	0.000459357	2	00:01:19	00:36:23	06:21:03
CNMG 120408	**	****	60	120	637	0.6	382	3.5	200	0.000363657	2	00:01:03	00:36:39	10:56:40

Cost Saved

Cost of insert (Nett)	Number of edges	Cost per edge	Number of parts	Cost per part	Qty produced	Total
£3.80	4	£0.95	6	£0.16	1000	£158.33
£2.94	4	£0.74	100	£0.01	1000	£7.35

Cost Saved	£150.98
Time Saved	06:21:03

Component Machining Study

Component description:
Pulley machine and type:
YoujiYV-1600ATC+C Ver

Workpiece material:
EN19

Using the correct product can reduce cutting times and reduce overall production cost per component.

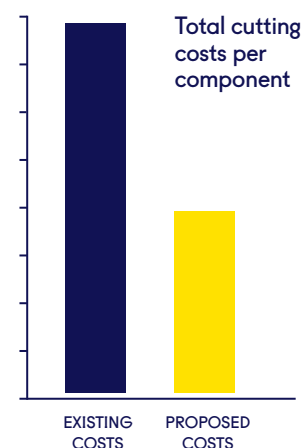
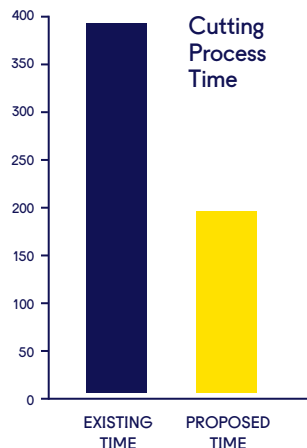

Working in partnership with leading suppliers



Rubix work with the leading suppliers in the cutting and machine tool sector. By taking an unbiased tooling approach we are able to recommend to our customers the best tools whatever their application, material or challenges.



> Your nationwide experts in metal removal and machining

Contact your local branch now on
how we can meet your cutting and
machine product needs, advice and
engineering solutions.

📞 0870 240 2100

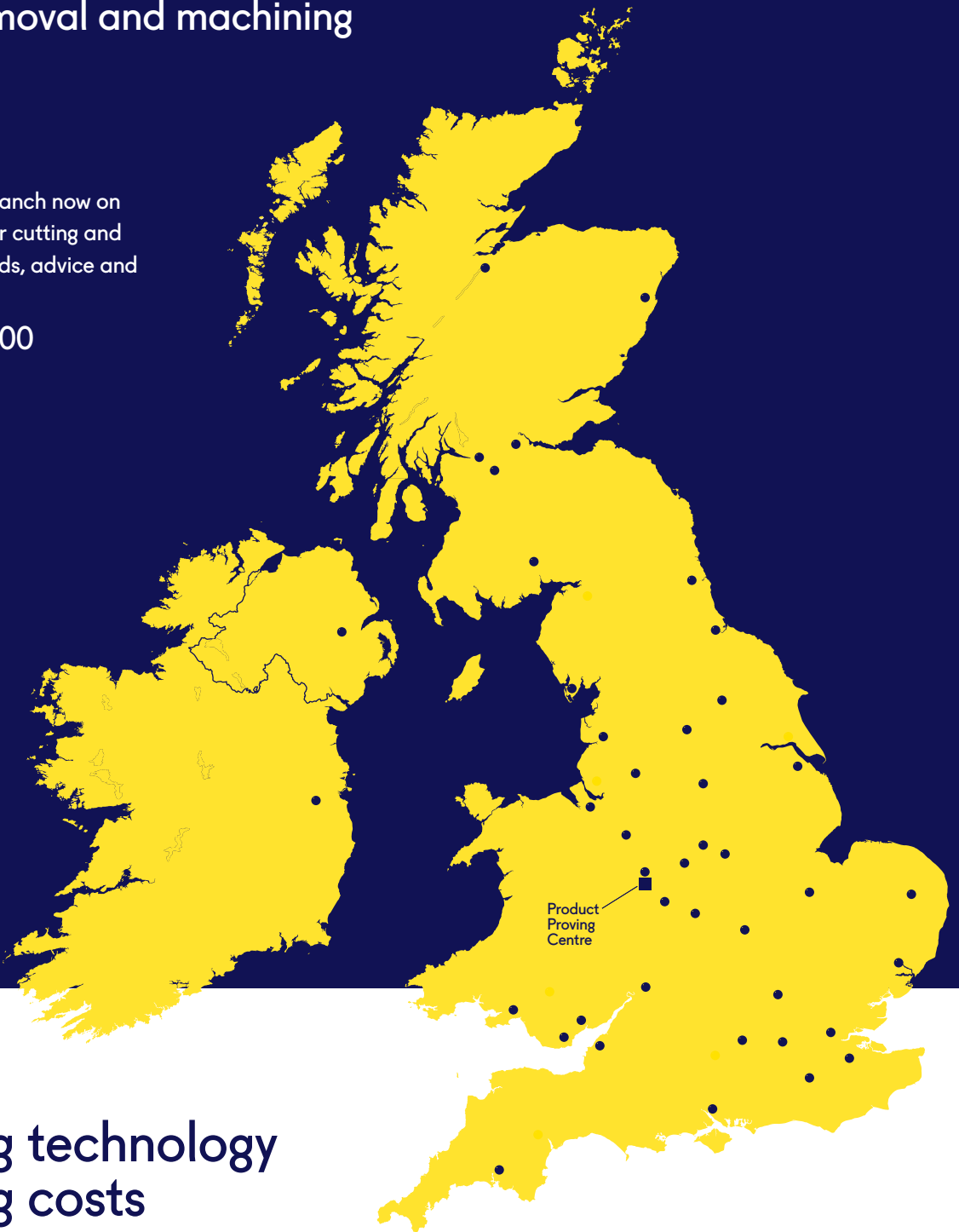

> cutting technology cutting costs

*With our specialist expertise, international strength and local presence –
combined with our thorough understanding of CAD/CAM, cutting tool
technology, fluid management and production processes we are ready to
keep you moving at optimum efficiency.*

Product Proving Centre
Rubix Engineering Centre
Unit 14 Dunstall Park
Wolverhampton
WV6 0PJ

uk.rubix.com



RUBIX
CUTTING &
MACHINING