

RUBIX



part of
your
success



Europe's #1 supplier of industrial maintenance,
repair and overhaul products, services and solutions

europa's no.1 and proud of it.



Manufacturing and industry demand outstanding support. Represented in 22 countries, we are Europe's leading industrial supplies specialist and we provide everything to help keep your business running at its optimum.

Rubix may be a new name, but our team have the same commitment that they've always had in adopting a creative and human approach to tackle our customers' challenges.

No one does parts like us. We offer more than 5 million different product lines – 500,000 of which are in stock at any one time.

As well as parts, we also believe in partnerships, and you can count on our team of experts to keep your machinery in order, your factory running, your people safe and your business successful.

We'll work as part of your team to reduce unplanned downtime and increase your efficiencies. Whether it's for engineering, assembly lines, manufacturing – whatever your needs – Rubix is the right choice for your business.

 part of
your
success



| 200+ Branch and
Insite™ locations

| 1 National
Distribution Centre

| 20+ Technical
Centres

| 2m products
in stock

| €2.4 billion sales
in 2020 Group-wide

right part. right price. right service.

Getting the part you need when you need it is critical. We understand how much our customers count on us to deliver, so we're committed to having exactly what you need in stock and immediately available, 24/7/365. Via our centrally-located National Distribution Centre in the Midlands and our network of branches across the UK, we'll get it to you on time and at the right price too.



Leaders in bearings and mechanical power transmission solutions

Working with the world's leading manufacturers, we can help you minimise downtime, extend the period between planned maintenance, improve performance all round, and help to reduce your energy consumption.

First for fluid power

We offer over 1 million individual lines and have the widest available range to ensure continuity of production. Our technical specialists ensure customers receive the right advice, provide on-site support and engineering solutions to improve production efficiency.

Industrial tools and consumables

Hand tools, machine tools, abrasives, adhesives... we hold over 13,000 tool products in stock from all the major brands. We've got the right tool for every application, with tool storage and all the advice you need too.

High-level protection without the high cost

There's no compromise on health and safety in the workplace which is why we stock a wide choice of protective clothing, equipment, hygiene products and workplace signage to keep you and your employees comfortable and safe as well as productive.

Mechanical Power

Transmission

- Bearings and Accessories
- Power Transmission
- Gearboxes and Motors
- Linear Motion
- Motion Control

Flow Technology

- Seals and Anti-vibration
- Pneumatics
- Hydraulics
- Process Equipment
- Flow Tech Instrumentation
- Filtration

Tools and General

Maintenance

- Tools and Metrology
- Fasteners and DIN-Parts
- Cutting Tools/Machining
- Welding, Brazing, Soldering
- Chemical Products
- Equipment
- Industrial Consumables

Health and Safety

- Head to Toe Protection
- Fall Protection
- Janitorial Supplies
- Hygiene Equipment
- Site Safety

no one knows the big brands like us.

> We work with thousands of suppliers including all the top OEM brands to source the highest quality products and services to support your operations.



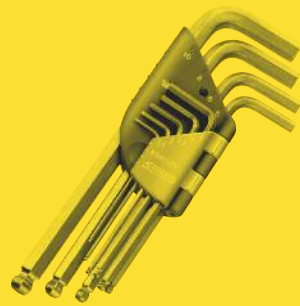

Our exclusive brands offer high quality alternatives to leading brand products.

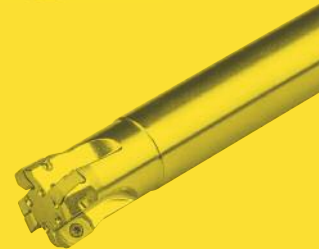



Meeting all your protection needs for less

GISS



Tools built for tough environments

Roebuck



High-quality parts to keep you moving

MECALINE



High-performance cutting tools you can trust

CUTLINE



Quality essentials at a better price

Spartex

Greater buying power means we can keep prices low without compromising on quality. Designed to meet all relevant industry standards and certification, with customer needs in mind. The range includes, Roebuck

for Hand and Air power tools, GISS for PPE, Cutline for Cutting and Grinding tools, Mecaline for mechanical and power transmission products, and Spartex for maintenance essentials.

Exclusively distributed by Rubix

RUBIX



expertise for every industry.

➤ We're leaders in providing services to industries as diverse as aerospace, aggregates and quarrying, automotive, chemicals, construction, glass, food and beverage, metals, paper and packaging, pharmaceuticals, transport, utilities – and more.

Technical expertise comes from having the best people. And Rubix people are passionate about providing a world-class personal service and providing the market-leading expertise that helps your business thrive. Product knowledge, sector-

specific engineering expertise and a close working relationship with the brands we supply puts us in the best possible position to be able to reduce your acquisition costs, help make your processes more efficient and reduce your working capital.

-  AEROSPACE
-  AUTOMOTIVE
-  CHEMICAL
-  CONSTRUCTION & AGGREGATES
-  ENGINEERING
-  FOOD & DRINK
-  HEALTH
-  MANUFACTURING
-  METALS
-  OIL & GAS
-  PETROLEUM
-  PHARMACEUTICAL
-  PULP, PAPER & PACKAGING
-  RECYCLING
-  TRANSPORT
-  UTILITIES
-  WASTE





advise.
apply.
advance.



Optimising product availability and driving production process improvements.

We provide more than just parts when and where you need them – we have extensive knowledge about products, performance and applications. So we can help our customers with added-value solutions to reduce costs and improve production efficiency right down to the individual plant and line level.

Our services

Technical and engineering services

-  Engineering solutions and automation
-  Condition monitoring
-  Maintenance & repair
-  Customisation, assembly and installation

Logistics services

-  Vendor Managed Services – Insite™, Instore™, Inscan™, Invend™
-  Inventory profiling
-  Consignment
-  Digital



geared to your success.

As part of our comprehensive services to industry we offer specialist workshop, repair and engineering services geared towards saving customers money. Our teams use their unrivalled levels of knowledge and engineering skill to help minimise repair downtime, always in the most cost-efficient way possible.

When running smoothly and productively, your business is a well-oiled operation. And we want to help keep it that way. We offer a specialist gearbox, pump and motor repair service that's fast, flexible and fits in around your needs to keep

downtime to a minimum. From providing spare parts to laser alignment, hydraulic cylinder manufacture and refurbishment, electromechanical repairs and condition monitoring, we're here to keep you moving and fully operational.

Our specialist gearbox, pumps and motors service

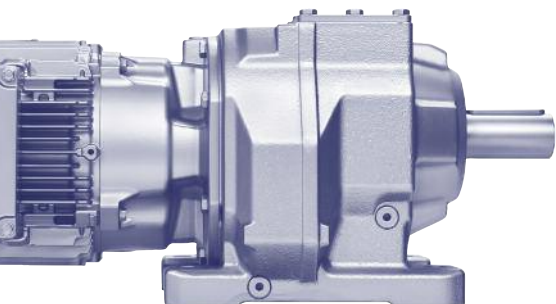

- › Free strip down and inspection repair quote with free collection and delivery service
- › 24/7 rapid repair and rebuild
- › Detailed reports and images
- › Expert support from reconditioning to new build
- › Genuine manufacturer parts or parts can be reverse engineered if obsolete
- › All bearings and seals changed with every reconditioned repair
- › 12 month warranty on every repair for full peace of mind



monitor, maintain and stay ahead of the game.

Our condition monitoring services provide your maintenance teams with detailed information about the health and performance of your plant machinery. By understanding when components or lubricants are deteriorating, you can schedule preventative maintenance to avoid costly downtime and expensive emergency repairs.



Air Leak Audit:
Our audit identifies ways to improve the efficiency of your compressed air system, saving you money.



Shaft and Coupling Alignment:
We can maximise the life and efficiency of your equipment by adjusting the alignment.



Belt Alignment and Tensioning Check:
This service improves the efficiency of your drive systems and ensures they are functioning optimally with proper alignment and tensioning.



Vibration Analysis:
Our Vibration Analysis allows early problem detection of wear, fatigue and failure in rotating machinery.



Thermal Imaging Survey:
We can complete a thermographic survey using a thermal imaging camera to identify faults and potential problems with machinery.



Lubrication Sampling:
Our oil sampling and analysis service helps to reduce costs by improving your equipment reliability and extending the life of your equipment.

To find out more about our engineering services, contact your local branch: 0870 240 2100

cutting tool solutions and application support.



- › Application Engineering solutions to our customers
- › Access to our practical tooling and training centre
- › The best solution for your applications
- › Closer working relationships with customers, technical experts and suppliers
- › The latest product innovations from leading suppliers
- › Engineered solutions and feature based projects

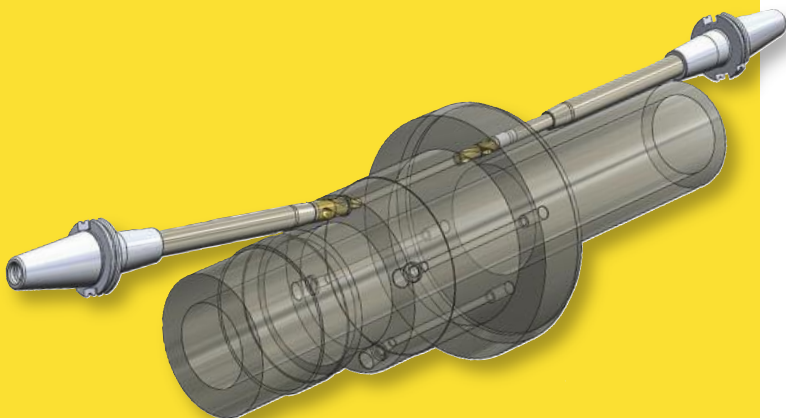

Delivering tangible cost savings

Our solutions will help you:

- › Reduce machining times
- › Increase tool life
- › Rationalise tooling usage
- › Improve productivity on high value applications
- › Optimise and improve processes

Services we provide

- › Remanufacturing and re-engineering
- › Holding and balancing – demonstrating benefits
- › Fluids and fluid management
- › Solutions for tool holding, work holding and tool storage
- › Feature based programming support
- › 2D and 3D CAD/CAM



On site Product Proving Centre and training

Our Product Proving Centre facilities include the latest CNC machines to trial the leading machining and tooling technology. Using real parts, with real tools on real machines, our specialist application team are able to demonstrate achievable savings for customers.

take advantage and take control.

Solutions that provide an all-round better way to manage your inventory:

The process of buying, restocking and managing fast-moving consumables can take up valuable time and money for any industrial or manufacturing business. Rubix Vendor Managed Services deliver significant time and cost savings, giving you greater control over budgets for consumable items. While we take care of your supplies your team have more time to focus on areas that add real value to your organisation.

Using our stock management expertise we will quickly analyse your processes and streamline your supplier base to consolidate your invoicing. We will also analyse your stock holding and design optimum ordering processes, creating efficiencies and making life easier for your entire workforce while giving you greater control and full management information.

Following our recommendations, we'll deliver a VMS solution to your exact requirements, based on one of our four proven solutions:

-  Reduce product consumption
-  Lower inventory cost
-  Improved productivity
-  Health & Safety compliance
-  Saving time
-  Straight forward installation
-  Reduce cost to purchase



Inscan™

An easy-to-implement stock check and replenishment system, the Rubix barcode stock replenishment system Inscan™ is perfect for all customers who require a low cost, uncomplicated inventory management solution.

Simply, Inscan™ gives you greater control over costs and improves the productivity of your team.

Invend™

Permanently stocked with your most in-demand industrial consumables, the Rubix Invend™ industrial vending machines provide 24/7 line-side access to the products your team needs to get the job done. No fuss, no waiting and no need to replenish – we keep track of everything and keep your Invend™ machine fully stocked for you. Choose Invend™ and benefit from a consumption reduction of up to 40% along with reduced inventory costs and improved productivity.

Insite™

Bringing our inventory expertise direct to your production line right where you need it – on your site. Strategically, Insite™ teams focus on helping you achieve cost savings by consolidating vendors and pro-actively delivering opportunities to reduce the total costs associated with your industrial supplies. Working full-time or part-time as part of your own day-to-day team, they also offer help with product identification and ordering, technical advice, supplier management and parts standardisation, plus improvement projects.

Instore™

Our industry leading stores management solution. Instore™ provides the ability to manage your stores inventory for both consumable and durable items. The Stores software provides real time transactional information through the use of wi-fi enabled scanners, whilst providing over 190 standard reports for all your reporting needs, and is also capable of integration with the majority of customers' ERP systems.

Reduce complexity, consolidate spend and simplify operations with our range of VMS solutions.

e-Solutions designed to fit your business needs.

For any industrial business, finding the right supplies is just a part of it: how you manage your orders and control your costs is vital too. Designed for speed, ease, control and cost efficiency, Rubix offers a multi-channel way to manage your industrial supplies procurement.

Whatever the size or scale of your business or operation, we have a solution for you, each delivering direct time, cost and reporting benefits. Our “Digital with a Human Touch” approach, together with our eProcurement experience makes us the natural partner to streamline your purchase process.

Rubix PunchOut:

Rubix PunchOut involves developing a fully integrated catalogue that links directly with your ERP to operate with your processes and workflows. Being web-based means they see your contracted pricing and real-time stock availability.

Rubix Personalised Webshop:

The Rubix Webshop provides a fully responsive user experience that works seamlessly on desktop, tablet or mobile. Real-time stock visibility means your purchasing team can see live availability and contracted price, whilst the high-quality search engine enables fast sourcing of required products. We design it to include your workflow processes and budget management – controlling who can buy what, when and for how much.

Rubix Public Webshop:

Our online store offers a convenient way to search for, order and buy MRO and tools and general maintenance products with real-time stock and order status data, plus a handy product comparison feature. With access to over 170,000 products from the world’s leading brands. It offers full card functionality, or you can purchase with your trade account.





> Which solution is right for you?

	 Rubix PunchOut	 Rubix Personalised Webshop	 Rubix Static Catalogue	 Rubix Public Webshop
Dedicated Assortment	✓	✓	✓	
Contract Prices	✓	✓	✓	✓
Workflow Validation	✓	✓	✓	
Includes eBilling	✓		✓	
Dedicated Human Touch	✓	✓	✓	
Real-time Product	✓	✓		✓
Real-time Prices	✓	✓		✓
Budget Compliance	✓	✓	✓	
Rich Content	✓	✓		✓
Supports Purchasing Cards		✓		✓
Track & Trace		✓		✓
Mobile Friendly	✓	✓		✓
Powered by EDI	✓		✓	

sharing our expertise



Our teams work with you to help increase your production uptime, reduce your total cost of ownership and streamline your transactions, to help achieve significant cost efficiencies and work towards a more sustainable future.

Here are some of the services and savings we've delivered to our customers recently.

Magna Exterior Systems – an Award-winning Air Leak Audit Survey

Magna Exteriors has a portfolio of products that includes access systems such as liftgates, exterior trim, modular systems, front-end modules including fascia, active aerodynamic systems and other lightweight structural components for automotive, commercial truck and other industrial markets. Magna Exteriors UK plant in Banbury, Oxfordshire invested in a Compressed Air System Audit, provided by Rubix.

Working with Magna Exterior Systems we introduced a Leak Detection Programme for the Compressed Air Systems. The system was analysed using state-of-the-art ultrasonic technology and a detailed photographic report on any leakage found in the system, showing the location, size and cost of each leak was provided. The customer's maintenance crew then took over to address the leaks using the report as a road map.

Paul Howard, Energy Improvement Co-Ordinator at Magna Exteriors:

“ The work Rubix has done for us has been great. Magna Exteriors has 325 plants across the world and is the second biggest car parts manufacturer. We have formal means of sharing best practice and energy saving solutions and recently I presented this compressed air service to my counterparts in Europe and they were very impressed. They will be looking to adopt this service Europe wide through Rubix. ”

At Magna Exterior Systems, the Audit resulted in **£130K savings over three years.** The company has gone from running three compressors full time to two, with the third for back-up. They are now using just two thirds of the energy and have reduced their servicing costs.



Delivering cost savings with Invend™ to leading Pharmaceutical Company

Adding Value

Rubix and Aesica have been working in close partnership through our Insite™ solution which helps customers achieve cost savings by consolidating vendors and pro-actively delivering opportunities to reduce the total costs associated with industrial supplies.

Aesica approached Rubix with the task of streamlining on-site products and ensuring all items were able to be fitted by an operator with no engineer required.

Previously, when the engineering stores were unmanned outside of daily working hours, the site engineers are called to access stores and book out parts required by the operators. However, as the engineering team operate a skeleton crew outside of daily working hours, operators may have a long wait for parts resulting in considerable downtime.

Creating Solutions

Following a full analysis of parts usage, we recommended Invend™, our industrial vending solution.

Invend™ provides 24/7 line-side access to the products the operators need to get the job done. We keep track of all products and keep the Invend™ machines fully stocked too. After successful implementation, Rubix has now installed several Invend™ machines across the whole of Aesica's High Capacity Manufacturing Facility (HCMF).

Providing Savings

During the first six months following implementation of Invend™, a total of 161 items have been vended, 103 of which were taken outside of normal working hours. This has saved operators considerable time and increased the operational availability of the HCMF.

- In just six months: 29 items have been used for the compressing machines saving a minimum of 25 hours downtime and increasing machine output by five batches.
- 25 items have been used on the coating machines saving a minimum of 21 hours and increasing machine output by 3.5 batches.
- 54 items have been used for general maintenance such as seals and gaskets, increasing the operator presence by a minimum of 42 hours.

Rubix has saved Aesica over £150,000 site wide.

engineering & technical centres

RUBIX ENGINEERING SERVICES



Part of RUBIX

Durham

Specialists in electrical motor rewinds, refurbishment and mechanical repair

SERVICES AND SOLUTIONS

- > Repair of gearboxes, pumps and motors
- > Fans
- > Clean pump cell
- > Generator, brake, clutch repair
- > Conditioning monitoring services

and more...



A RUBIX Company

Southampton Portsmouth, Chatham

Experts in electro-mechanical services

SERVICES AND SOLUTIONS

- > Repair of gearboxes, pumps and motors
- > Fans and blowers
- > Screw conveyors
- > Condition monitoring
- > Laser alignment for couplings

and more...



A RUBIX Company

West Bromwich Luton, Middlesbrough

Engineering repair & replacement providers

SERVICES AND SOLUTIONS

- > Repair of gearboxes, pumps and motors
- > Fans and blowers
- > Screw conveyors
- > Condition monitoring including vibration, thermal and oil

and more...



Part of RUBIX

Gloucester, Newport, Swanscombe & Portishead

Specialist hydraulics services supplier

SERVICES AND SOLUTIONS

- > Repair of hydraulic pumps and motors
- > Condition monitoring
- > Hydraulic product installation
- > Engineering design services

and more...



Compressed Air Ltd

A RUBIX Company

West Midlands (9 locations)

Compressed air system optimisation specialists

SERVICES AND SOLUTIONS

- > Repair and replacement of pumps, motors, fans, blowers and shafts
- > Air and pipe system installation
- > Air control system manufacture
- > 24/7/365 call out

and more...



A RUBIX Company

5 UK technical competency centres

Specialists in engineering and workshop services

SERVICES AND SOLUTIONS

- > Repair and replacement of gearboxes, pumps, motors, fans, blowers and shafts
- > Electrical installation
- > Welding
- > Fabrication services
- > Condition monitoring

and more...

RUBIX MOTION CONTROL & AUTOMATION



A RUBIX Company

Gloucestershire

Suppliers of industrial automation products

SERVICES AND SOLUTIONS

- > Industrial automation specialists in linear motion, pneumatics, aluminium extrusion and actuator system products
- > In-house machine shop enables full customisation of its product offering including cutting of precision linear rail and the machining of ground and rolled ball screws

and more...



A RUBIX Company

Leicester

Aluminium profile and components specialist

SERVICES AND SOLUTIONS

- > Industrial automation specialists in linear motion, pneumatics, aluminium extrusion and actuator system products
- > In-house design team (CAD design)
- > In-house machine shop enables full customisation of its product offering

and more...



RUBIX CUTTING & MACHINING



Nottingham



UK's largest technical distributor of cutting tools

SERVICES AND SOLUTIONS

- > Technical and standard cutting tools and associated products
- > Time-served application engineers
- > All major leading cutting tool brands
- > Engineered solutions working with leading CAD/CAM systems
- > Feature based programming support

and more...



Airdrie, Tyne & Wear



Experts in industrial and metal cutting tools

SERVICES AND SOLUTIONS

- > Technical and standard cutting tools and associated products
- > Time-served application engineers
- > All major leading cutting tool brands
- > Manufacture of bespoke cutting tools
- > As-New regrind service

and more...



Newton Abbot



Value-added experts of cutting tools and solutions

SERVICES AND SOLUTIONS

- > Technical and standard cutting tools and associated products
- > Time-served application engineers
- > All major leading cutting tool brands
- > Vending Solutions

and more...

RUBIX

Wolverhampton

Engineering experts in cutting and machining

SERVICES AND SOLUTIONS

- > Technical and standard cutting tools and associated products
- > Category management team offering product support and sourcing
- > On-Site technical support
- > Own brand development
- > Product proving and training centre

and more...

committed to ethical and environmental practices.



Ethics and the environment are at the heart of everything we do. We make every effort to reduce our impact on the environment and to promote good environmental practice. We are fully committed to making a positive contribution to the well-being of our employees, customers and community, as well as the planet.

Single use plastics reduced



Plastic jiffy bags replaced with 100% paper/pulp jiffy bags



Bubble wrap and air bags replaced with craft paper



Plastic sellotape replaced with 100% paper tape



Plastic bottled soft drinks replaced with cans in vending machine



Picking bags replaced with 100% degradable sugar cane bags



2,200 plastic milk containers replaced with cardboard cartons in NDC canteen each year



Plastic pallet wrap replaced with pre-stretched pallet wrap, reducing usage by 40%



Environmentally-friendly 'document enclosed' wallets used

Commitment to sustainability

- EcoVadis silver medal holder for business sustainability ratings. We are in the top 25% in our industry
- Signatory to UN Global Compact initiative
- CIPS Certification in Standard of Excellence in Procurement Policies and Procedures
- ISO 14001 (environmental) certification
- ISO 45001 (Health & Safety certification)

Clear commitments and a roadmap to increased disclosure and improved reporting.

Recycling and waste

100% of cardboard is recycled



Damaged pallets and wood packaging are repaired or recycled into wood chippings for gardens



Out of date rubber is chipped and made into children's playground surfacing material



Spent cutting and grinding discs become the anti-slip additive in specialised paint coverings

ESG

Environmental Social Governance

How we think about ESG

It's our commitment to the environment and society

ENVIRONMENTAL

- Reducing waste, energy, packaging in our business, and with our customers and suppliers

SOCIAL

- Health and safety, employee engagement, training and compliance in areas including anti-bribery and corruption

GOVERNANCE

- Diversity, executive pay and supply chain management

Why ESG matters to our business

It's becoming more important to our stakeholders

EMPLOYEES

- An important factor when considering where to work e.g. wellbeing and safety.
- A key driver of engagement

CUSTOMERS AND PROSPECTS

- Increasingly becoming the difference between winning and losing.
- ESG is a factor in new contract and renewal negotiations.
- EcoVadis is important, but ESG is about much more than that.

SUPPLIERS

- Our reputation depends on the people and organisations we choose to do business with.
- We require suppliers to sign up to a new code of conduct.

INVESTORS

- Consider ESG factors when deciding whether to invest.
- Many will not invest unless they can see our commitment and progress.

3

Our three part approach

- 1** Maximise efficiencies of scale to minimise environmental footprint
- 2** Investing in the development of a skilled and engaged workforce
- 3** Supporting our customers in their sustainability journeys

Rubix – Europe's no. 1 industrial supplies specialist.

RUBIX

Whilst customers are able to enjoy all the benefits brought by working with a large multinational, we also enjoy delivering the personal service of a local-branch network too.

Our service runs through a network of branches, all specially equipped to meet the particular needs of local industries.

We also operate a purpose-built National Distribution Centre in the Midlands – centrally located to enable us to deliver the right product at the right time, wherever you are.

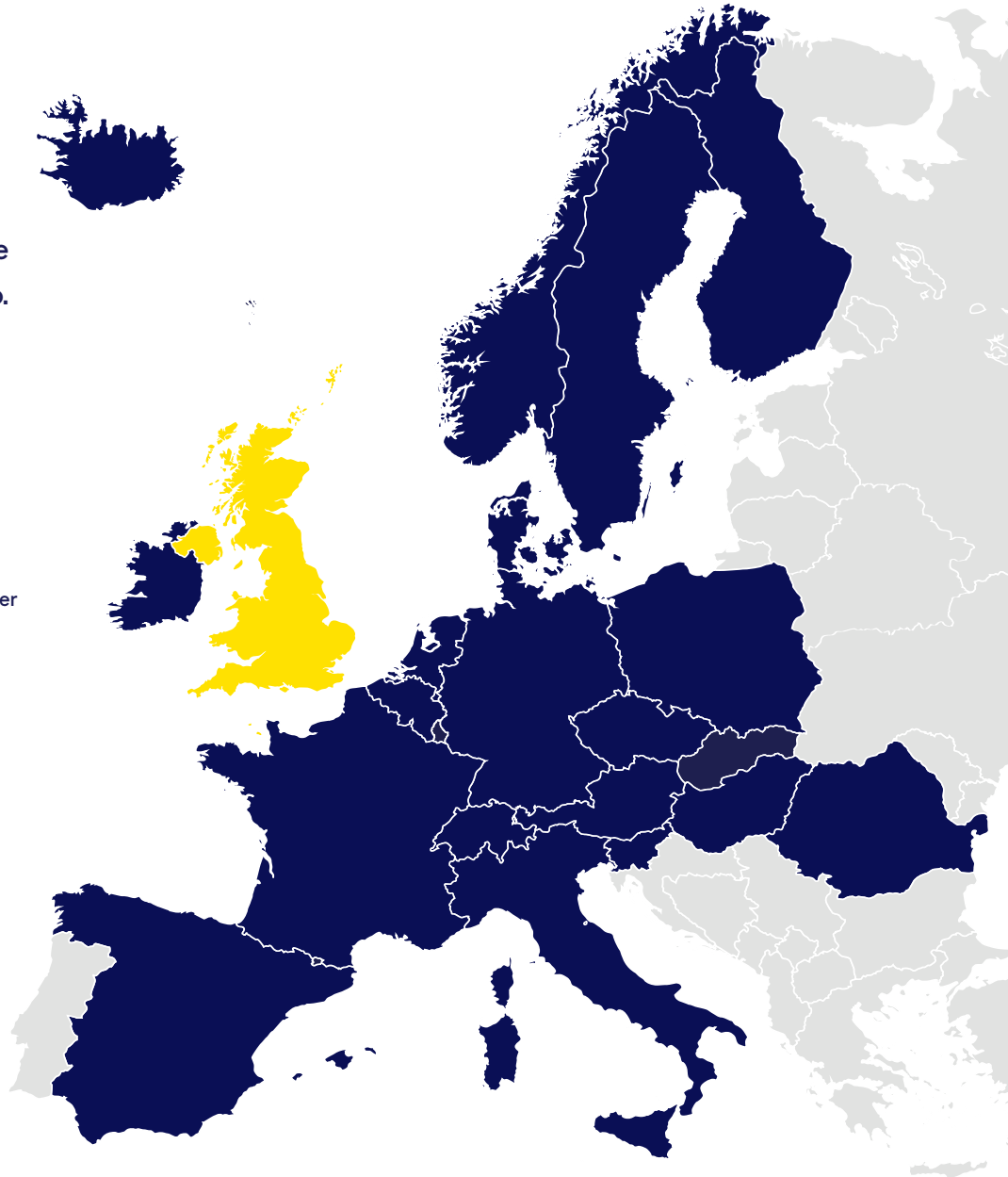

For more information about our products and services contact your local branch direct:

📞 0870 240 2100 or visit

🌐 uk.rubix.com

to find your local branch.



**part of
your
success**